

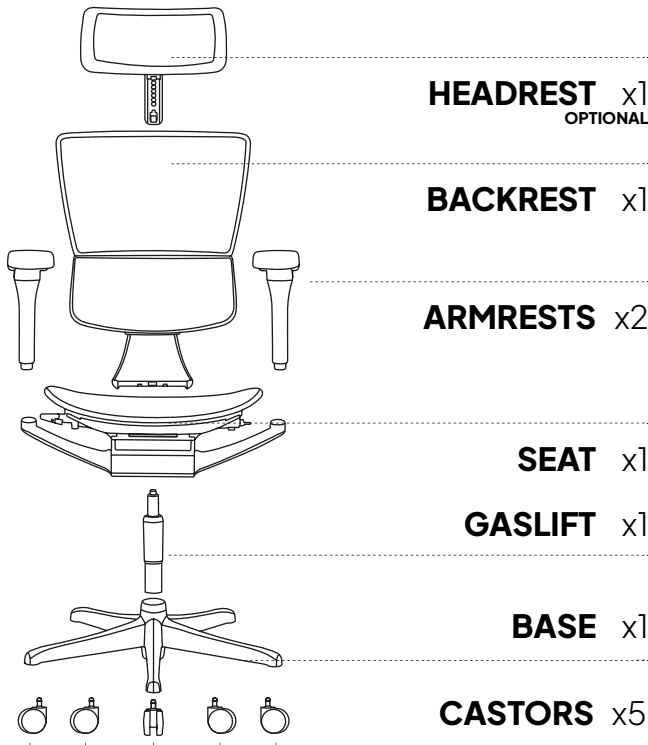

MIRUS ELITE G2 ASSEMBLY GUIDE

COMFORT.GLOBAL



ALLEN KEY



SCREWS FOR ARMRESTS
4+1 SPARE

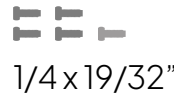

SCREWS FOR BACKRESTS
4+1 SPARE



ASSEMBLE YOUR CHAIR

STEP 1

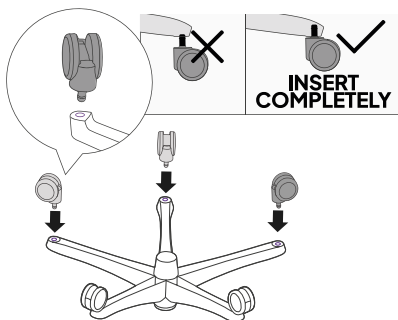

STEP 2

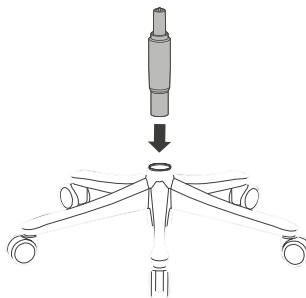

STEP 3

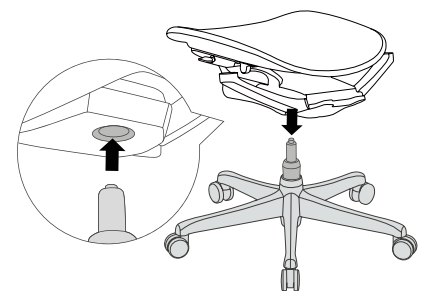

STEP 4

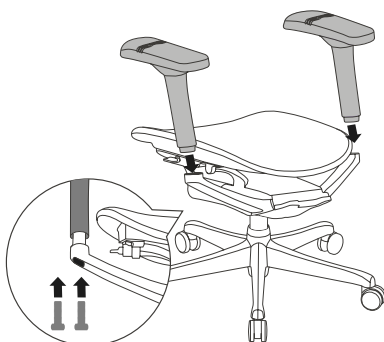

STEP 5

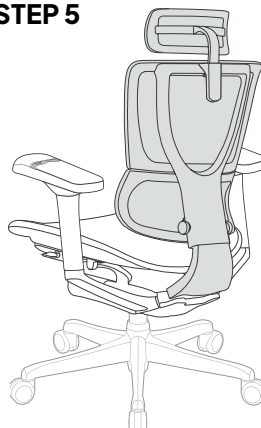

OPTIONAL HEADREST

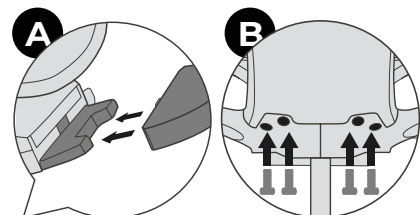

ATTENTION
ALIGN AT SCREW HOLES THEN
FIX THE BACKREST CONNECTOR
USING THE FOUR M8 SCREWS



MIRUS ELITE G2

ADJUSTMENT GUIDE

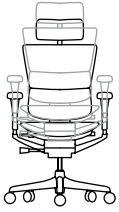

SEAT HEIGHT

Lever on right

To lower, lift lever while seated.
To raise, take your weight off chair and lift lever.



FORWARD SEAT TILT

Lever on left (free-float* mode on)

Push left lever down at the front and lean back to release forward seat tilt. Return right lever to neutral position to lock seat angle and back.



SEAT DEPTH

Lever on right

Push lever forward while seated. Slide seat until positioned with a 3 cm gap between front of the seat and the back of your legs.



ARMREST HEIGHT

Armrest ratchet

Lift or lower the armrests to your preferred height. This helps avoid shoulder and neck tension.

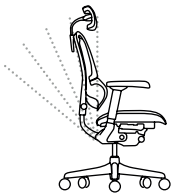

BACKREST RECLINE

Lever on right

Push the lever back while seated and recline. Leave lever back if using free-float mode*, or return to the centre to lock in one of 4 reclined positions.



ARMREST DEPTH

Armpad slide

Slide the armpads forwards or backwards for customised support of your forearms, taking pressure off your shoulders.



RECLINE TENSION

Long spindle on right

With the single lever pushed back, rotate long spindle forward to increase and backwards to reduce recline resistance.



ARMREST TILT

Armpad bend

Tilt up the front of your armrests for comfortable wrist support, ideal for when using handheld devices or reading a book.

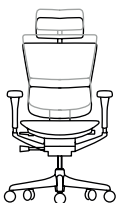

BACK HEIGHT

Knobs at rear of backrest

Reach behind the chair and lift or lower the backrest to comfortably fit the backrest and lumbar to the shape of your spine.



ARMREST WIDTH

Armpad slide

Slide the armpads out or in so your shoulders and arms sit naturally by your side with your elbows close to your body.



LUMBAR TENSION

Dial on backrest

Turn the dial towards the large dots to strengthen the lumbar support's pressure, and towards the small dots to reduce it.

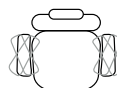

ARMREST ANGLE

Armpad twist

Pivot the armpads inwards and outwards to help you position your shoulders, neck, forearms, and hands for mouse and keyboard work.

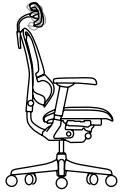

OPTIONAL HEADREST ANGLE

Pivot

Pivot the angle of the headrest to support your neck and head as you recline.



OPTIONAL LEGREST EXTENSION

Legrest handles

Turn the wheels at either sides to release the legrest. Lift the legrest frame and unfold out the mesh legrest.

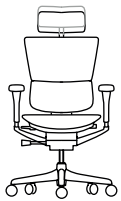

OPTIONAL HEADREST HEIGHT

Lift and lower

Lift or lower the headrest to fit comfortably into the curve of your neck.



COAT HANGER

Pop up/down

Lift the arms to pop the coat hanger up, and press the button under the centre to drop the arms.





HEALTHY POSTURE

Comfort is passionate about healthy seating. Our chairs are engineered to minimise pressure and tension on your back, neck, shoulders and thighs, reducing the risk of musculoskeletal issues and pain.

Set up your chair correctly to promote healthy posture and enjoy the benefits of certified ergonomic seating.

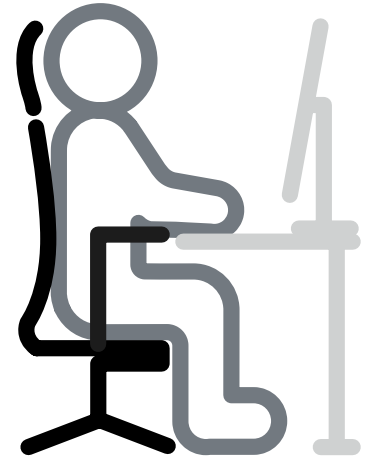

SEAT

- Adjust the seat height so your feet rest flat on the floor and your thighs are parallel to the floor.
- Set the seat depth to fit the length of your thighs and so there's a 3 cm gap between the seat front and the back of your knees.
- Activate the seat tilt feature to support your thighs when leaning in to your desk.

BACK & LUMBAR

- Set the recline tension to personalise the resistance of the backrest when leaning back in free-float mode.
- The backrest can be locked in position, but we recommend using free-float mode to encourage balanced and dynamic movement as you work.
- Set the back height so it supports the curves and natural alignment of your spine and lumbar region.
- Adjust the lumbar tension so it supports the natural alignment of your spine and provides lower back comfort.

ARMRESTS

- Set the armrest height, width and depth so your arms comfortably make contact with the armpad. Your elbows should be close to your body and your shoulders relaxed.
- Pivot the chair's armpads in for support while using a keyboard or using a handheld device, and out to support mouse use.

OPTIONAL HEADREST

- Set the height and angle of your headrest to support the curve between your neck and the back of your head.

OPTIONAL LEGREST

- Elevate your legs when reclining using the fold-out legrest.
-